

# TVAN®

## THE TVAN® CONCEPT:

The all new Tvan® Mk4 shares the same off-road 'DNA' as its predecessors, with several improvements including larger cabin space, more head room above the bed, refined electrics, 2 kitchen configurations and more storage.

The principal features of the Tvan® such as the quick erect tent, stored in its own compartment (not on the bed) and the dynamically styled body which today still continues to set it apart from the rest, has not been compromised.

Each Tvan® model retains the same key characteristics such as MC2 Suspension®, hot dipped galvanised chassis, durable riveted steel and aluminium construction of the cabin and lower body lockers, aluminium rear folding platform (deck), off-road electric brakes and fully articulated off-road coupling etc.

All other specifications, options and accessories are up to you. This process allows you to customise your Tvan® to match your tow vehicle's capabilities, your camping preferences and budget.

The models are identifiable by their highlighted colours; Yulara (blue), Tanami (green), Canning (red) and Murrarji (orange).

Simply select a Tvan® model that best suits your needs, add options and you are on your way.

## STANDARD SPECIFICATION

### SUSPENSION, CHASSIS AND BODY:

- Industry leading off-road hot dipped galvanised chassis with genuine military grade MC2 Suspension®
- Proprietary aluminium sandwich panel wall construction
- Off-road electric brakes and hand brake
- DO35, 3.5 tonne fully articulated off-road coupling
- Aluminium checker plate drawbar step with spirit level
- Aluminium checker plate on rear deck for safe and easy access
- LED tail lights and side clearance markers
- Rear wood rack
- 108L steel protected plastic food grade tank with in-line grit filters
- 2x side panniers for 20L jerry cans (40L total)

### POWER:

- Roof mounted 40W solar panel with regulator
- Voltmeter
- 105ah deep cycle AGM battery, fused and wired to anderson plug connection
- Interior Command Console (ICC) fascia with master switch & individual circuit switching
- 12V merit, cigarette and USB plugs integrated within ICC

# TRACK.

T R A I L E R

- ✓ AUSTRALIAN OWNED & MADE
- ✓ 5 YEAR SUSPENSION & CHASSIS WARRANTY
- ✓ GENUINE AUSTRALIAN MILITARY HISTORY
- ✓ MULTI-AWARD WINNING
- ✓ HIGHLY REGARDED

## NOTHING COMPARES!



### DRAWBAR:

- Drawbar stone deflectors
- 4x jerry can holders
- Spare wheel mount & tyre / gas bottle cover

### OUTDOOR LIVING:

- Sail awning

### KITCHEN:

- Classic Kitchen /stainless steel slide out 2 burner kitchen, including sink and plumbed water, 2x 4kg gas bottles and mounts
- External light over kitchen
- 12V merit plug in kitchen locker

### INTERIOR REFINEMENTS:

- Twin roof hatches with integrated blinds and insect screens
- Genuine Australian made Wax Converters canvas (Dynaproofed)
- Rear tent stored in hatch (not on the bed)
- Window curtains
- Queen size high density foam mattress
- LED light in tent
- LED reading lights - adjustable and individually switched with a master override
- Internal tool box and security lock box
- Storage locker lighting
- Insulated wall panels and fabric lined roof

Buying a Track Trailer® Tvan® has never been easier. New for 2016 Track Trailer® has improved the ever popular Tvan® MK4 with all new models and options.

Simply select a Tvan® Model that best suits your needs and add selected individual items from our extensive options and accessory lists.

The models are a combination of the most commonly ordered options and accessories. These Models represent the best value with a significant discount applied to all options within them.

Listed options can also be added or upgraded on any model.

<b>SELECT A MODEL TO BEGIN:</b>	<b>YULARA</b>	<b>TANAMI</b>	<b>CANNING</b>	<b>MURRANJI</b>
<b>ALL MODEL PRICING INCLUDES THE SELECTED PACKAGES BELOW, FREIGHT, REGISTRATION AND PRE DELIVERY. NO MORE TO PAY - TOW AWAY</b>	<b>\$50,700</b>	<b>\$55,300</b>	<b>\$59,700</b>	<b>\$73,400</b>
<b>KITCHEN:</b>				
Classic Kitchen /stainless steel slide out 2 burner kitchen, including sink and plumbed water, 2x 4kg gas bottles. External light over kitchen & 12V merit plug in kitchen locker.	<b>STD</b>	<b>STD</b>	N/A	N/A
Kitchen extension shelf quickly and easily attaches to the wheel arch creating more space for utensils and condiments and also provides a tea towel hanger.	OPT	<b>STD</b>	N/A	N/A
Upgrade to Premium kitchen : Larger prep spaces, more storage. 3 burner cook top & glass top sink with flick-mixer tap, easy to use windshield & Piezo ignition	OPT	OPT	<b>STD</b>	<b>STD</b>
<b>POWER:</b>				
Upgrade 60W solar panel	OPT	<b>STD</b>	<b>STD</b>	<b>STD</b>
Battery management display upgrade	OPT	<b>STD</b>	<b>STD</b>	<b>STD</b>
15A battery charger	OPT	<b>STD</b>	<b>STD</b>	<b>STD</b>
2x outside 240V kitchen outlets	OPT	OPT	OPT	<b>STD</b>
<b>DRAWBAR STORAGE:</b>				
Front boot: Equipped with 2 sealed lockers accessible on the LHS and RHS. The LHS is standard with a sliding fridge drawer, insulation ,12V power and venting. The RH compartment is fitted with a pressure switch activated LED light.	OPT	OPT	OPT	<b>STD</b>
RHS slide out tray with tie down points	OPT	OPT	OPT	<b>STD</b>
<b>INTERIOR REFINEMENTS:</b>				
Roof storage system	OPT	<b>STD</b>	<b>STD</b>	<b>STD</b>
Side wall storage pockets	OPT	<b>STD</b>	<b>STD</b>	<b>STD</b>
Rear insect screen (30sec setup)	OPT	<b>STD</b>	<b>STD</b>	<b>STD</b>
3 speed fan with timer	OPT	<b>STD</b>	<b>STD</b>	<b>STD</b>
Additional fan 3 speed fan with timer	OPT	OPT	<b>STD</b>	<b>STD</b>
Fabric lined bed head	OPT	OPT	<b>STD</b>	<b>STD</b>
Under mattress liner	OPT	OPT	<b>STD</b>	<b>STD</b>
Stereo system	OPT	OPT	<b>STD</b>	<b>STD</b>
LHS pannier storage (internal)	OPT	OPT	<b>STD</b>	<b>STD</b>
Tent upgrade (set of 3 windows)	OPT	OPT	OPT	<b>STD</b>
Under bed middle drawer	OPT	OPT	OPT	<b>STD</b>
Under bed LHS drawer	OPT	OPT	OPT	<b>STD</b>
Diesel hot water & heating	OPT	OPT	OPT	<b>STD</b>
Ensuite tent	OPT	OPT	OPT	<b>STD</b>
Tropical roof (in lieu of catch net)	OPT	OPT	OPT	<b>STD</b>
<b>OUTDOOR LIVING:</b>				
Awning roof	OPT	<b>STD</b>	<b>STD</b>	<b>STD</b>
Awning end wall	OPT	<b>STD</b>	<b>STD</b>	<b>STD</b>
Awning fridge wall	OPT	<b>STD</b>	<b>STD</b>	<b>STD</b>
<b>STYLE:</b>				
Alloy Wheels upgrade to CSA Stampede or Magnum 16x8	OPT	OPT	OPT	<b>STD</b>
Colour choice	OPT	OPT	OPT	<b>STD</b>

# INDIVIDUAL OPTIONS LIST:

## KITCHEN:

Kitchen Shelf (Classic kitchen only)	\$225
Premium kitchen: (upgraded from the Classic kitchen)	\$2,860
<ul style="list-style-type: none"> <li>Larger prep spaces, more storage</li> <li>3 burner cook top &amp; glass top sink with flick-mixer tap</li> <li>Easy single handed windshield</li> <li>Piezo ignition</li> </ul>	

## PREMIUM REFINEMENTS:

Sliding glass windows (fly or sandfly mesh)	\$2,800
Diesel heating & hot water and shower rose (not including the ensuite)	\$5,600
Air conditioner, under bed, 240V	\$3,880
Innerspring pillow top mattress upgrade	\$600
Ultimate pocket spring mattress upgrade	\$650
GPS tracker (Black Knight)	\$600
Customise external highlight colour and internal drawer trim colour (10 to choose from)	\$400
AM/FM/CD/MP3 Player	\$765
2nd water tank - 70L	\$1,400
Draw water from an external source, including hose and mounting plug – runs though taps and hot water (does not fill tanks)	\$400

## STANDARD DRAWBAR:

Front pivoting tray / wood rack (required for mounting bike racks)	\$620
1x Bike rack (max 2, requires front pivoting tray)	\$460ea.
Drawbar storage tray & cover for portable toilet	\$235

## FRONT BOOT:

Front boot: Equipped with 2 sealed lockers accessible on the LHS and RHS. The LHS is standard with a sliding fridge drawer, insulation, 12V power and venting. The RH compartment is fitted with a pressure switch activated LED light.	\$3,900
RHS sliding drawer, with tie down points	\$490
Front boot shelving: short or long - 440mm or 510mm above slide	\$350
RHS venting & power (for a 2nd fridge)	\$255
Drawer swap RHS to LHS (for longer fridges)	\$115
Engel Posi-Lock Socket in Fridge compartment	\$50
Front storage box bike mounting brackets (add bike racks)	\$925
1x Bike rack (max 4, requires mounting brackets)	\$450ea.

## INTERNAL OPTIONS:

Roof storage system	\$470
Side wall storage pockets	\$350
Fan - 3 speed with timer 12V	\$300
Fabric lined bed head	\$275
Under mattress liner	\$300
Bed tie down rails (pair)	\$150
Fabric lined rear tent hatch	\$370
Interior canvas seats (pair)	\$220
Hatch mounted entry light (above tent door)	\$125

## POWER :

Solar power 60W fixed upgrade	\$265
Battery monitor upgrade from voltmeter	\$380
Battery charger 7 stage 15A fitted	\$390
Battery - 2nd 105Ah + 25A charger	\$1,150
40Amp DC to DC Redarc 12V charger + solar	\$760
Inverter 300W pure Sine - fitted	\$380
Installation of 2nd battery wiring for future upgrade	\$240
240V outlets x2 at kitchen	\$280

## TENT:

Rear insect screen - with door	\$340
Rear canvas screen upgrade- with mesh window/door	\$275 /\$615
Additional tent windows x3	\$700
Zip on family room tent with solid vinyl floor	\$1,225
Ensuite tent (purchased with diesel hot water)	\$600
Ensuite tent	\$745
Tropical roof (in lieu of catch net)	\$450

## OUTDOOR LIVING:

Sail awning	\$420
Awning roof, kitchen end & fridge wall	\$1,860
Separate 2nd end wall (tent end)	\$345
Window upgrade per wall (end wall)	\$260
Separate draught skirt	\$425
Separate front wall with 2 x windows & door	\$1,215

## STORAGE:

LHS inside pannier storage bin	\$315
Lockable outside pannier doors x1 (max 2, not dust proof)	\$200ea.
Under bed storage box 40 litre (each)	\$30
Under bed drawer storage system (all 3 drawers below) - sheet metal construction and removable for easy packing	\$1800
<ul style="list-style-type: none"> <li>LHS drawer</li> </ul>	\$650
<ul style="list-style-type: none"> <li>LHS drawer to suit for air conditioning option</li> </ul>	\$700
<ul style="list-style-type: none"> <li>Middle drawer</li> </ul>	\$700
<ul style="list-style-type: none"> <li>RHS drawer</li> </ul>	\$650
Maxtrax mounting brackets (rear deck)	\$120
Maxtrax available in blue, green, red and orange to match your Tvan	\$299
Portable toilet	\$225

## SUSPENSION & CHASSIS:

Underbody spare wheel carrier	\$650
1.8 Tonne suspension upgrade & 12" brakes	\$1,200
Spring package to suit tyres 33" diameter	\$370
Electronic stability control	\$1,450
Alloy wheel 16x8 upgrade CSA Stampede	\$400
ALKO Ratchet jockey with solid wheel	\$485
Underbody protection mudflaps	\$365

## DRAWBAR STORAGE OPTIONS:

The Yulara and Tanami are delivered standard with a drawbar frame that has provision for up to 4x jerry cans, 2x gas bottles & 1x spare wheel. It's also fitted with large metal stone guards to protect the body and a dust cover for the spare and gas bottles. Options also include a wood carrier and bike racks.

The Murrnaji comes standard with the Front Boot featuring two separately sealed compartments, one for generic storage and the other with a dedicated fridge slide and constant 12V power.

The fridge compartment also features filtered air vents. This boot accommodates a spare wheel and 2x gas bottles.

There are many additional options available including, a RHS slide out tray, dual venting and power for up to 2 fridges, a fridge slide swap (RHS to LHS) for longer fridges and an optional height LHS shelf.

### STANDARD DRAWBAR:

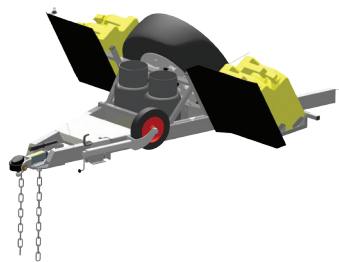

### FRONT BOOT OPTION:

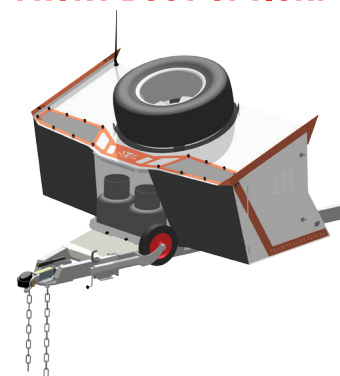

### BIKE RACK OPTIONS:

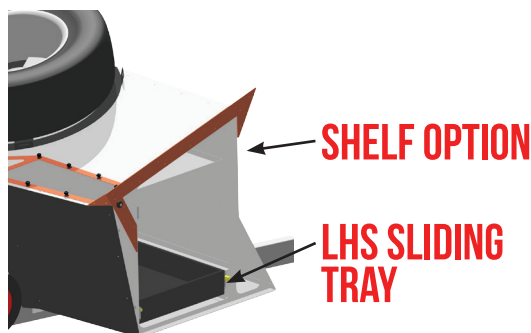
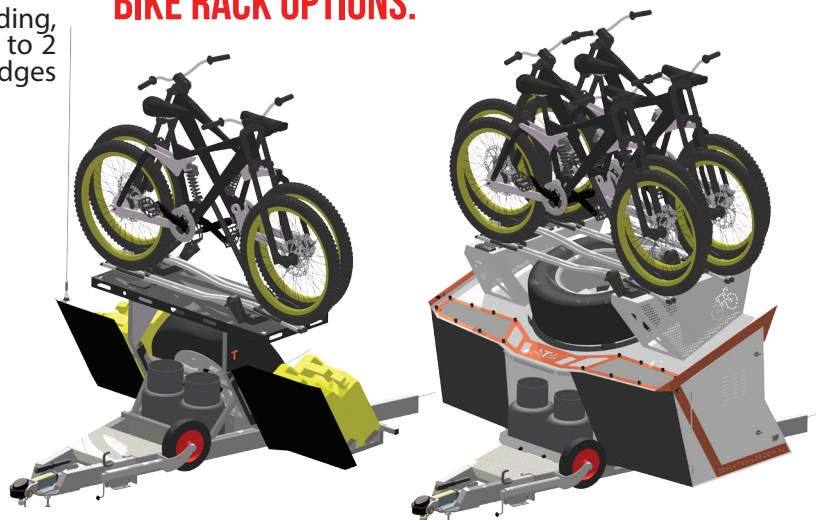

SHELF OPTION

LHS SLIDING TRAY

## WEIGHTS: (APPROX.)

### Yulara Tanami Canning Murrnaji

Tare mass with the standard drawbar package	940	950	1000	N/A
Load capacity	560	550	500	N/A
Ball weight	90	95	100	N/A
Tare mass with Front boot package fitted	975	985	1030	1075
Load capacity with Front boot package fitted	525	515	470	425
Ball weight with Front boot package fitted	115	120	125	130

Weights will change with the addition of optional extras. Please consult your nearest Track Trailer dealer for advice on the towing restrictions of your vehicle.

## TRAVEL SPECIFICATIONS:

Overall length in travel mode	4900
Overall width	1920
Height unladen	2050
Interior setup length	4800
Tent area size (on the deck)	1700x2000
Wheel track	1650
Departure angle	30°

Suspension travel	250
Axle capacity	1600kg
Water tank	108L
2nd water tank (optional)	70L
Jerry cans	Up to 6
Hot water (optional)	20L

All pricing and model information is correct at the time of print 10/01/2017.

Subject to TRACK TRAILER® (Harvey Technology PTY LTD) Standard Terms and Conditions of Sale.

Price based on delivery, including registration and GST in highlighted state - Top RHS of the models page.

**TRACKTRAILER.COM.AU**

**TRACK TRAILER**  
1/640 DORSET RD, BAYSWATER VIC  
03 8727 6100  
SALES@TRACKTRAILER.COM.AU